

1 Nov., 2012

UNCEFACT



Requirements Specification Mapping (RSM)

Business Domain: Travel/Tourism

Business Process: Small scaled Lodging House Reservation Information Process

Title: TT&L Small scaled Lodging House Reservation Information Process Project

UNCEFACT Forum: Sectoral

Version: 1.0

Release: R.12B

Status: Draft

Reference Documents

- UMM Meta Model Core Module (Candidate for 2.0) 2009-01-30
- UMM Meta Model Foundation Module (Candidate for 2.0) 2009-01-30
- Core Components Technical Specification-Part 8 of the ebXML Framework V2.01(15 Nov. 2003)
- Core Components Technical Specification Technical Corrigendum V2.01, 12 Feb. 2007
- Core Components Data Type Catalogue V2.1 2008-04-08
- XML Naming and Design Rules 2.0 17 Feb., 2006
- UML Profile for Core Components, V1.0, Final Specification, 2008-01-16
- UN/CEFACT CC Library Version 2012 A
- UN/CEFACT Business Requirements Specification Version 1.5 (CEFACT/ICG/005)
- UN/CEFACT Requirements Specification Mapping (Documentation Template Guidelines) Version2.0

Change History

Date of change	Version	Paragraph changed	Summary of changes
10 April, 2012	0.1 Original		
12 Oct., 2012	D1.0	Chapter 4.1	Updates of Class Diagram CCs Spreadsheet BIEs Spreadsheet
1 Nov., 2012	1.0	Chapter 4.1 Chapter 7	Update of Class Diagrams Message Assembly added

Requirements Specification Mapping

Table of Contents

<i>Reference Documents</i>	2
<i>Change History</i>	3
<i>Table of Contents</i>	4
<i>1. Objective</i>	5
<i>2. Definition of Terms</i>	5
<i>3. Target Technology Solution</i>	5
<i>4. Information Payload to be Implemented</i>	5
<i>4.1 Conceptual Data Model</i>	5
<i>4.2 Canonical Data Model</i>	6
<i>5. Business Information Entity Reference</i>	6
<i>6. Core Components Developed and their UN/CEFACT Registry Version Used</i>	7
<i>7. Logical Message Structure</i>	7

1. Objective

The objective of this document is to identify the complete set of the class diagrams to be used to transform the business requirements shown in the BRS (Small Scaled Lodging House Reservation Information Process 17 Oct., 2012) into the target technology solutions expressed in this document

2. Definition of Terms

All terms are defined in the said BRS.

3. Target Technology Solution

The target technology is XML schema and is based on UN/CEFACT Technical Specification Version 2.

4. Information Payload to be Implemented

4.1 Conceptual Data Model

The class diagrams of Small scaled Lodging House Reservation Information Process are shown in the following figures. Figure 1 shows Lodging House Reservation Class in Lodging House Reservation Request and Response Message, and Figure 2 shows all the relevant classes in Lodging House Reservation Class.

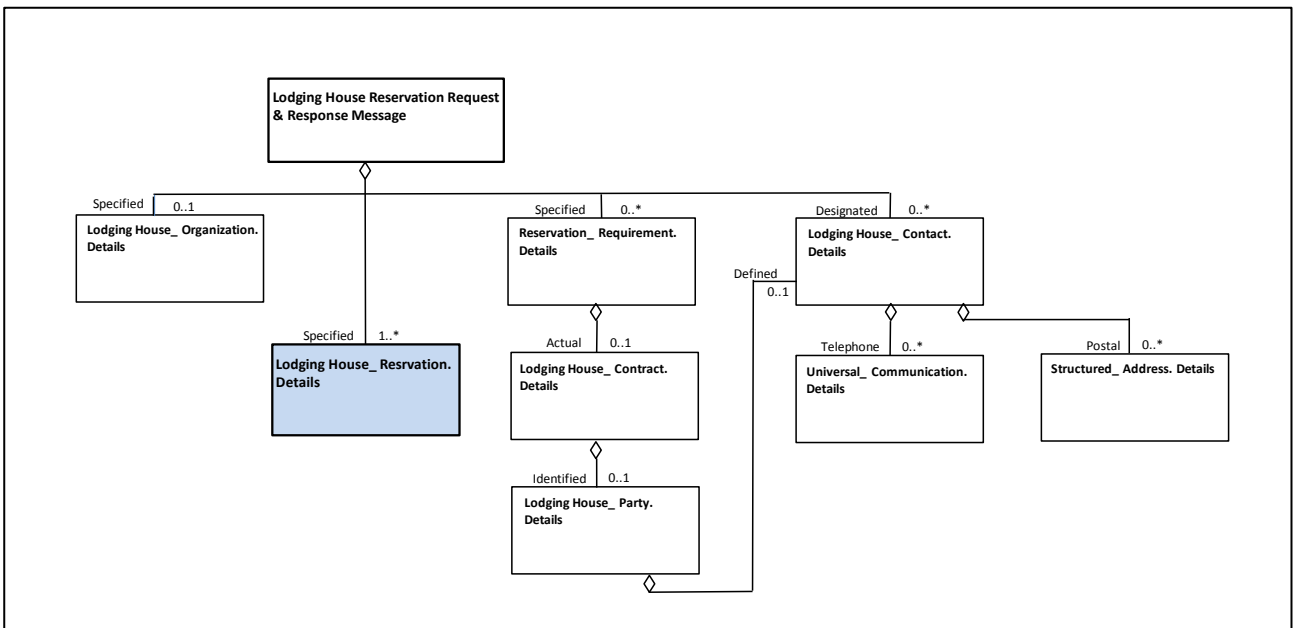

Figure 1 Class Diagram of Lodging House Reservation Class in Lodging House Reservation Request and Response Message

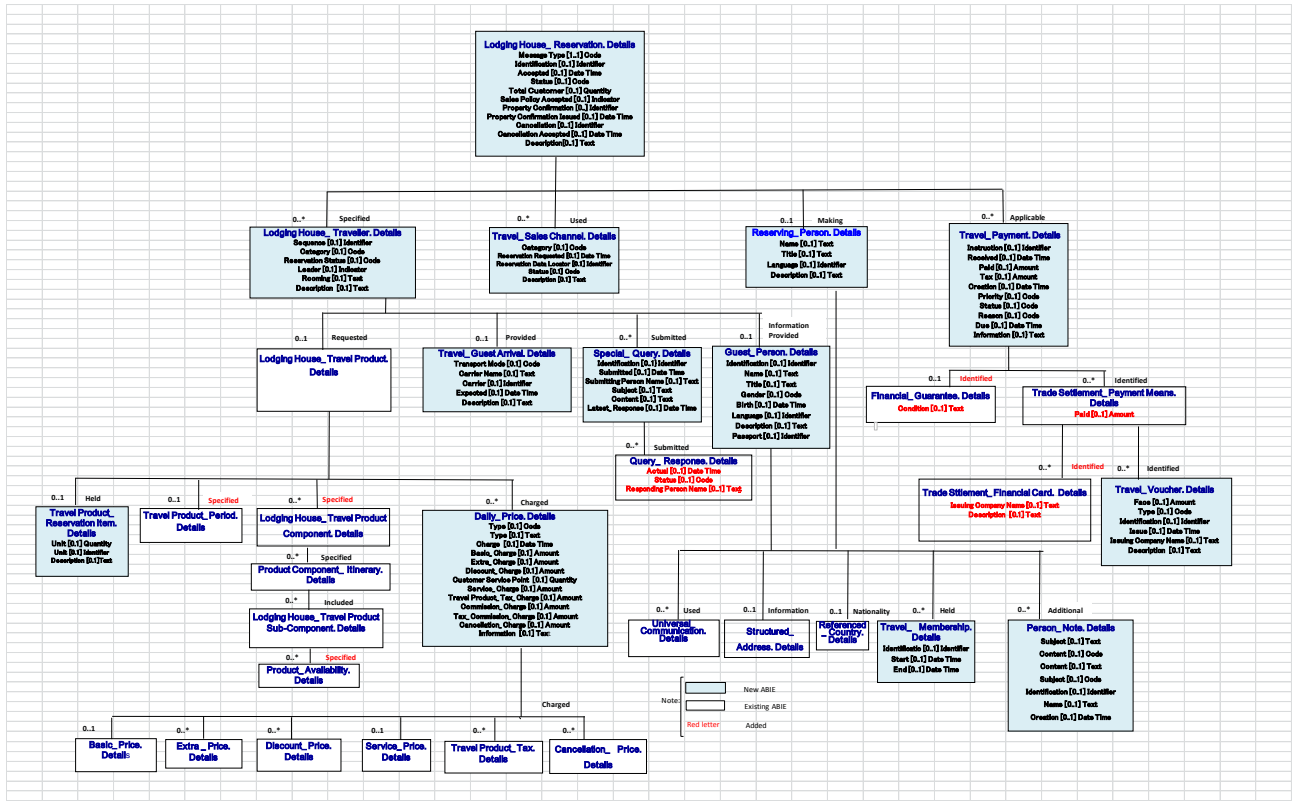

Figure 2 Class Diagram of Lodging House Reservation Class with its sub-classes.

4.2 Canonical Data Model

The Canonical Data Model is the same as in the Conceptual Data Model.

5. Business Information Entity Reference

All the business information entities developed for this process, including ABIEs, BBIEs, and ASBIEs, are shown in the file embedded in this chapter in the form of UN/CEFACT harmonization template.



SLHResrvationBIE2
0121101.xlsm

6. Core Components Developed and their UN/CEFACT Registry Version Used

The Core Component Library version used in this document is D12A. All the core components developed for this process, including ACCs, BCCs, and ASCCs, are shown in the file embedded in this chapter in the form of UN/CEFACT harmonization template.



SLHReservationCC
20121101.xls

7. Logical Message Structure

The Message Assembly is shown in the file embedded in this chapter, which is based upon the message structure for Lodging House Reservation Request and Response Message shown in Figure 1.



SLHMAforReservati
onRQandRS121101.

(End)